



AGENDA
REGULAR MEETING
2/19/2026 5:30 pm
Meeting Location
17967 Bushard St
FV Senior Center

Hyundai Grant Committee – N/A

- Day of Service – Jynene Johnson
- Fountain Valley Royal Regiment Boosters Association – Jackson Lai

Zoom Link: <https://fountainvalley.zoom.us/j/86511715481>

CALL TO ORDER – 5:30pm

ROLL CALL

PRESENTATIONS (5 Minutes Each)

New Board Member Welcome - Taylor

PUBLIC COMMENTS ON SCHEDULED ITEMS ONLY

INFORMATION / ACTION ITEMS

1. January Minutes - Taylor
2. January Financials – Iovine
3. Board Officer Appointments (President/Treasurer/Secretary) – Taylor
4. FVCF Board of Director Appointment (2 Open Seats) - Crandall
5. Board Leadership Structure Co-Chair Assignments – Grandis

DIRECTOR UPDATES (3 Minute Reports/Discussion)

General Discussion/Events

- Honored Hero Banner Program Update – Crandall
- Non-Profits Poker – Montz
- Invitation to attend Murder Mystery Fund Raising – Montz
- Egg Hunt Fundraising – Taylor
- Promotional Swag - Kuisel

Grants/Sponsorship Request

- Interfaith Day of Service
- Fountain Valley Royal Regiment Boosters Association
- Memorial Bench – Fire Chief Bill McQuaid (Ratification)

VERBAL / WRITTEN CORRESPONDENCE

None

GENERAL / PUBLIC COMMENTS

CLOSED SESSION

ADJOURNMENT

Next Regular Meeting Scheduled – 3/19/26 at the Center at Founders Village



AGENDA
MEETING MINUTES
1/15/2026 5:30 pm
Meeting Location
17967 Bushard St
FV Senior Center

MEETING MINUTES 1/15/2026

Hyundai Grant Committee – N/A

- No Grant Presentations

Zoom Link: <https://fountainvalley.zoom.us/j/86511715481>

CALL TO ORDER – 5:31pm

ROLL CALL

- Bob Kuisel, Barbra Montz, Alaina Knight-Hougen, Larry Crandall, Matt Taylor, Kasie Hanley, Jane Iovine, Glenn Grandis, Rob Frizzelle, Susan Castellanos (5:44pm)

PRESENTATIONS (5 Minutes Each)

- None scheduled for January

PUBLIC COMMENTS ON SCHEDULED ITEMS ONLY

- None

INFORMATION / ACTION ITEMS

1. December Minutes – Frizzelle
 - Motion by Crandall, 2nd by Montz; Passed 9-0
2. November/December Financials – Iovine
 - Motion by Grandis, 2nd by Kuisel; Passed 10-0
3. Approve 2025-2026 Budget – Iovine
 - Motion by Grandis with amendments to poker revenues at \$19,000 for fall and spring events, 2nd by Crandall; Passed 10-0
4. Board Officer Appointments – Frizzelle
 - Motion by Taylor to appoint Taylor as Past President, Iovine as Treasurer, Frizzelle as Secretary, 2nd by Crandall; Passed 10-0
 - Table President Elect appointment
5. Board Leadership Structure Co-Chair Assignments – Grandis
 - Schedule board retreat related to Board Leadership Positions, assignment to those positions, following City Council board appointments. Item tabled to next meeting.

DIRECTOR UPDATES (3 Minute Reports/Discussion)

- Montz provided an update on the funeral service for past FVCF Board Member Jan Heisterman.
- Montz invited the FVCF Board to the upcoming FV Women's Club Murder Mystery play and will present a grant request at a future meeting for board consideration.

General Discussion/Events

- Sports Basement Gift Card \$250



AGENDA
MEETING MINUTES
1/15/2026 5:30 pm
Meeting Location
17967 Bushard St
FV Senior Center

- Board direction to use the \$250 Spots Basement gift card for a poker prize. Director Castellanos will purchase the prize.

Grants/Sponsorship Request

- Mr. Fountain Valley – Taylor
 - Motion by Frizzelle to sponsor a table at the Mister FV event for \$1,000, 2nd by Crandall; Passed 10-0.
- KinderVision Golf Tournament
 - Ratification of sponsorship of a 3some for the Kinder Vison Golf Tournament; Passed 7-0 by email vote.
 - Request for sponsorship information earlier next year.
- Plavan PTO Outdoor Ed
 - Motion by Grandis to award \$1,000 Grant for Playan PTO Outdoor Ed by Grandis, 2nd by Castellanos; Pass 9-1 (Constantine No).

VERBAL / WRITTEN CORRESPONDENCE

None

GENERAL / PUBLIC COMMENTS

CLOSED SESSION

ADJOURNMENT

Next Regular Meeting Scheduled – 2/19/26 at the Center at Founders Village

Statement of Financial Position
 FOUNTAIN VALLEY COMMUNITY FOUNDATION
 As of January 31, 2026

DISTRIBUTION ACCOUNT	TOTAL
Assets	
Current Assets	
Bank Accounts	
Cash	
Checking Account	15,562.39
FVCF - CD	168,265.20
Money Market Account	241,644.46
Operation Santa Clause Account	2,625.88
Petty Cash	0.00
Total for Cash	\$428,097.93
Total for Bank Accounts	\$428,097.93
Accounts Receivable	
Accounts receivable	12,575.00
Pledges Receivable	1,250.00
Total for Accounts Receivable	\$13,825.00
Other Current Assets	
Undeposited funds	0.00
Total for Other Current Assets	\$0.00
Total for Current Assets	\$441,922.93
Fixed Assets	
Accumulated depreciation	-1,318.35
Office equipment	7,910.12
Total for Fixed Assets	\$6,591.77
Total for Assets	\$448,514.70
Liabilities and Equity	
Liabilities	
Current Liabilities	
Accounts Payable	
Accounts payable	2,305.00
Accrued Expenses	0.00
Total for Accounts Payable	\$2,305.00
Total for Current Liabilities	\$2,305.00

Statement of Financial Position
 FOUNTAIN VALLEY COMMUNITY FOUNDATION
 As of January 31, 2026

DISTRIBUTION ACCOUNT	TOTAL
Long-term Liabilities	
AAPI Luau	2,240.00
Adults with Disabilities	1,884.00
Advisory Committee for Persons with Disabilities	3,750.00
Boys and Girls Club Expansion	22,810.06
Cameron Scholarship	5,253.34
Concerts in the Park	40,094.83
Dia De Los Muertos	250.00
Easter Egg Hunt	16,807.18
FV Chamber	0.00
Great FV Campout	-7,329.21
Hall of Fame	0.00
Halloween Decorating Contest	100.00
Honored Heros Banner Program	1,060.50
Hop On Senior Transportation	6,040.00
Hyundai 5K	7,534.02
Hyundai Grants	19,274.36
Lunar New Year Appreciation	670.70
Monster Hunt	100.00
Movies in the Park	950.00
Operation Santa Claus	3,025.88
Other City Programs	600.00
Poker Tournament	0.00
PREP Program	15,058.32
Senior Expo Liability	8,690.00
Senior Services-Senior Center	7,002.30
Spark of Love	0.00
Sports Park Softball	1,150.00
Summerfest	35,924.20
Summerfest Reserve	26,353.00
Tree Lighting	6,053.81
Tree Lighting Décor	2,146.93
UAP	96,927.26
Total for Long-term Liabilities	\$324,421.48
Total for Liabilities	\$326,726.48
Equity	
Opening balance equity	110,538.81
Retained Earnings	-1,823.66
Net Income	13,073.07
Total for Equity	\$121,788.22
Total for Liabilities and Equity	\$448,514.70

FOUNTAIN VALLEY COMMUNITY FOUNDATION

Budget vs. Actuals: Budget_FY26_P&L - FY26 P&L

July 2025 - January 2026

	TOTAL			
	ACTUAL	BUDGET	OVER BUDGET	% OF BUDGET
Revenue				
FVCF Event Income				
Fall Poker Tournament Income	14,675.89	15,000.00	-324.11	97.84 %
FVCF Corn Booth Income		0.00	0.00	
Hall of Fame Income	13,345.84	8,500.00	4,845.84	157.01 %
Spring Poker Tournament Income		0.00	0.00	
Summerfest Income to FVCF	4,574.00	9,000.00	-4,426.00	50.82 %
Total FVCF Event Income	32,595.73	32,500.00	95.73	100.29 %
Other FVCF Income				
Corporate Donations	730.80	2,916.69	-2,185.89	25.06 %
Event Processing Fees	961.55	5,133.31	-4,171.76	18.73 %
Individual Donations	530.98	1,458.31	-927.33	36.41 %
Interest income	6,992.37	9,916.69	-2,924.32	70.51 %
Other Income	865.91	0.00	865.91	
Total Other FVCF Income	10,081.61	19,425.00	-9,343.39	51.90 %
Pass Through Sponsorship Income				
API Luau	150.00		150.00	
Concerts in the Park Sponsors	13,750.00		13,750.00	
Dia De Los Muertos	250.00		250.00	
Disabled Dances	150.00		150.00	
Easter Egg Hunt Sponsors	1,500.00		1,500.00	
Hop on Senior Transport	670.00		670.00	
Hyundai Hope on Wheels Sponsorships	500.00		500.00	
Lunar New Year	150.00		150.00	
Movies in the Park	1,950.00		1,950.00	
P.R.E.P. Program Sponsorship	2,000.00		2,000.00	
Senior Expo Sponsors	4,150.00		4,150.00	
Sportspark-Softball Sponsors	500.00		500.00	
Summerfest Sponsors	2,000.00		2,000.00	
Tree Lighting Ceremony Sponsors	5,980.00		5,980.00	
Total Pass Through Sponsorship Income	33,700.00		33,700.00	
Speciality Income				
Hyundai Hope On Wheels Income	109,058.26		109,058.26	
Summerfest Event Income	42,921.00		42,921.00	
Total Speciality Income	151,979.26		151,979.26	
Total Revenue	\$228,356.60	\$51,925.00	\$176,431.60	439.78 %
GROSS PROFIT	\$228,356.60	\$51,925.00	\$176,431.60	439.78 %
Expenditures				
FVCF Event Expenses				
Fall Poker Tournament Expenses	4,779.17	10,000.00	-5,220.83	47.79 %
FVCF Corn Booth Expense	109.19	0.00	109.19	
Hall of Fame Expenses	7,324.27	7,000.00	324.27	104.63 %

FOUNTAIN VALLEY COMMUNITY FOUNDATION

Budget vs. Actuals: Budget_FY26_P&L - FY26 P&L

July 2025 - January 2026

	TOTAL			
	ACTUAL	BUDGET	OVER BUDGET	% OF BUDGET
Other Event Expenses	463.33	676.69	-213.36	68.47 %
Spring Poker Tournament Expenses		0.00	0.00	
Tree Lighting Booth Expense	719.82		719.82	
Total FVCF Event Expenses	13,395.78	17,676.69	-4,280.91	75.78 %
Grants and Donations				
City Event Sponsorship Expense		14,600.00	-14,600.00	
Community Event Participation/Sponsorship	6,700.00	5,000.00	1,700.00	134.00 %
Grants	2,160.00	12,500.00	-10,340.00	17.28 %
Total Grants and Donations	8,860.00	32,100.00	-23,240.00	27.60 %
Other Business Expenses				
Advertising & marketing		1,458.31	-1,458.31	
Bank and credit card fees	1,331.05	40.81	1,290.24	3,261.58 %
Insurance	1,347.00	466.69	880.31	288.63 %
Membership Dues	365.00		365.00	
Other Operating Expenses		682.50	-682.50	
PO Box Rental	374.22		374.22	
Software Expense	1,890.15	1,633.31	256.84	115.73 %
Supplies	248.99	350.00	-101.01	71.14 %
Volunteer Support	1,792.08	1,750.00	42.08	102.40 %
Total Other Business Expenses	7,348.49	6,381.62	966.87	115.15 %
Pass Through Sponsorship Expenses				
API Luau Sponsors	150.00		150.00	
Concerts in the Park Sponsors	13,750.00		13,750.00	
Dia De Los Muertos	250.00		250.00	
Disabled Dance Sponsor Expense	150.00		150.00	
Easter Egg Hunt Sponsors	1,500.00		1,500.00	
Hop On Senior Transport	670.00		670.00	
Hyundai Hope on Wheels Sponsors	500.00		500.00	
Lunar New Year Sponsors	150.00		150.00	
Movies in the Park Sponsors	1,950.00		1,950.00	
P.R.E.P. Program Sponsorship Expense	2,000.00		2,000.00	
Senior Expo Sponsors	4,150.00		4,150.00	
Sportspark-Softball Sponsors	500.00		500.00	
Summerfest Sponsors	2,000.00		2,000.00	
Tree Lighting Sponsors	5,980.00		5,980.00	
Total Pass Through Sponsorship Expenses	33,700.00		33,700.00	
Specialty Expenses				
Hyundai Hope on Wheels 5K Expenses	109,058.26		109,058.26	
Summerfest MOU Expenses				
Non Profit Wristband Payout	300.00		300.00	
Summerfest Advertising	4,007.37		4,007.37	
Summerfest Bar Expenses	11,217.80		11,217.80	
Summerfest Carnival Expense	2,942.41		2,942.41	

FOUNTAIN VALLEY COMMUNITY FOUNDATION

Budget vs. Actuals: Budget_FY26_P&L - FY26 P&L

July 2025 - January 2026

	TOTAL			
	ACTUAL	BUDGET	OVER BUDGET	% OF BUDGET
Summerfest Facility Expenses	8,694.00		8,694.00	
Summerfest Income Distribution per MOU	15,759.42		15,759.42	
Total Summerfest MOU Expenses	42,921.00		42,921.00	
Total Specialty Expenses	151,979.26		151,979.26	
Total Expenditures	\$215,283.53	\$56,158.31	\$159,125.22	383.35 %
NET OPERATING REVENUE	\$13,073.07	\$ -4,233.31	\$17,306.38	-308.81 %
NET REVENUE	\$13,073.07	\$ -4,233.31	\$17,306.38	-308.81 %

BYLAW X OFFICERS

1. Officers

The officers of the corporation shall be President, **President Elect or Immediate Past President**, Secretary, and Treasurer and such other officers as the Board of Directors may elect. Those officers shall serve without compensation. All officers except the Secretary shall be members of the Board of Directors. The Board may also elect a Chief Executive Officer who shall manage the day to day activities of the corporation as a salaried employee who shall not be a member of the board or an employee, officer or elected official of the City of Fountain Valley. Any number of offices may be held by the same person, except that neither the Secretary nor the Treasurer may serve concurrently as either the President or the Chairman of the Board.

2. Election of Officers

The officers of the corporation, except those appointed in accordance with the provisions of Section 3 of this Article X, shall be chosen by the Board of Directors, and each shall serve at the pleasure of the Board. **Terms of office for Secretary and Treasurer are two years. The term for the President will last four years as the President will serve as the President Elect, President, and Immediate Past President.**

Year 1: President Elect

Year 2: President

Year 3: President

Year 4: Immediate Past President

Each January the Board of Directors will engage in elections and/or approve the role changes.



Fountain Valley Community Foundation

Building Community, Strengthening Lives

Board of Directors 2026

President

Matt Taylor

wcdebate@aol.com

Board Appointed: Nov. 2024 - 2026

Past President

Larry Crandall

FVCrandall@icloud.com

Council Appointed: 2025 - 2027

Treasurer (Vote Pending)

Jane Iovine

janeanniovine@gmail.com

Council Appointed: 2025 - 2027

Secretary

Robert Frizzelle

rob.frizzelle@fountainvalley.org

Council Appointed: 2025 - 2027

Director

Barbara Montz

bjmontz1@mac.com

Council Appointed: 2025 - 2027

Director

Alaina Knight-Hougen

akdance02@gmail.com

Council Appointed: 2025 – 2027

Director

Susan Castellanos

susan@loscab.com

Council Appointed: 2025 - 2027

Director

Mary Ellen Pascucci

mepascucci@gmail.com

Council Appointed 2026 - 2028

Director

Kim Constantine

kim.constantine@fountainvalley.gov

Council Appointed 2026 (Annual)

Director

Kasie Hanley

KasieHanley@mac.com

Board Appointed: November 2024 – 2026

Director

Wallace Rodecker

wallace@rodecker.com

Council Appointed 2026 - 2028

Director

Bob Kuisel

bobkuisel1@gmail.com

Board Appointed: 5/6/2025 - 2027

Director

Glenn Grandis

glenn.grandis@gmail.com

Board Appointed: 5/6/2025 - 2027

* City Council Alternate – Ted Bui

** FVCF Board Appointment Seats – 2 Available

Agenda Item: Board Leadership Structure – Co-Chair Assignments
Discussion / Action Item

Background:

To strengthen engagement, accountability, and leadership across all Foundation initiatives, it is proposed that **every Board Member serve as a Co-Chair** for at least one key area of the Foundation. Each area will have **a minimum of two Board Members serving as Co-Chairs**, ensuring continuity, collaboration, and shared responsibility.

These leadership roles may be tied to Foundation events, operational functions, or strategic initiatives.

Potential Co-Chair Areas Include (but are not limited to):

- Poker Tournament
- Summerfest Booth
- Fundraising & Development
- Social Media & Marketing
- Treasurer / Financial Oversight
- Campout
- Hall of Fame
- Honored Heroes Program
- Volunteer Committee
- Capital Campaign
- Endowment Development

Responsibilities of Co-Chairs May Include:

- Planning and oversight of assigned area or event
- Coordination with staff, volunteers, and committees
- Reporting updates to the Board
- Helping recruit volunteers and resources as needed

Proposed Structure:

- Each leadership area will have **at least two Board Members** serving as Co-Chairs
- Board Members may serve in more than one area if appropriate
- Assignments may be reviewed annually or as needed

Recommended Action:

Discuss and approve the Co-Chair leadership model and begin assigning Board Members to leadership areas.



Community Grant Application CHECKLIST PAGE

Funded by Hyundai Motor America, The grant program will be distributed through the Fountain Valley Community Foundation in accordance with set guidelines. Applicants must live in or serve the community of Fountain Valley.

1. Complete one original Grant Application Form. Please answer all questions on the application. Spaces are limited in order to help applicants be brief and specific in response to requested information and for the Grant Committee to be able to evaluate numerous grant applications. A cover letter is not encouraged or necessary.
2. Board of Directors List: A listing of current officers, board members and executive director that includes their name, city of residence and professional affiliation. (Include in original application as well as all 4 copies).
3. Financial Information:
 - A. The most current audited or internal financial statements (only one copy to be included with the original application).
4. IRS 501(c)3 letter or copy of your IRS determination letter (only one copy to be included with original application)
5. Application requirements
 - A. Original should be in a file folder labeled with the name of the agency applying.
Original application should include: Board of Directors List, optional newsletter or brochure, audited financials, IRS letter.
 - B. Four *copies* (original + four copies) of application DO NOT need to be in file folders. All copies should be three-hole punched, DO NOT staple, DO NOT copy double side.

____ I have read How to Apply for a Grant Guidelines. (Please check-off the following and include this checklist with the original application only.)

INSTRUCTIONS: Read checklist before filling out application. There are 8 sections in this application. Complete each section and attach required documents as instructed.

Legal Name of Organization _____

Date of IRS Exemption(include IRS letter only w/ original application)_____

Address _____ City _____ State _____ Zip _____

Telephone _____ Website _____

Name of Executive Director _____

Name and Title of Person Submitting this Application _____

Telephone _____ Email Address _____

Number of Paid Staff Full Time Staff Part Time Staff _____

IRS Classification (please check the appropriate box):

501(c)3 - Public Charity 501(c)3 - Private Foundation Not 501(c)3 If not, specify _____

BRIEFLY BULLET POINT YOUR KEY PROGRAMS AND SERVICES

BRIEFLY DESCRIBE THE ORGANIZATION'S KEY INITIATIVES, ACCOMPLISHMENTS AND/OR CHALLENGES OVER THE PAST TWO YEARS. INCLUDE ANY INTERNAL OR EXTERNAL EVALUATION MECHANISMS USED TO EVALUATE YOUR PROGRAM (#ADMISSIONS/PEOPLE SERVED, THIRD PARTY EVALUATIONS/AUDITS

DO YOU AGREE TO PROVIDE A NARRATIVE ON THE IMPACT OF THIS PROJECT/EVENT ON THE COMMUNITY OR YOUR ANTICIPATED AUDIENCE? _____



BRIEFLY DESCRIBE THE PROJECT FOR WHICH FUNDING IS SOUGHT

Amount requested from FVCF _____

What is the total budget for this project. _____

If this project is part of a bigger project please attach the total budget worksheet in the original application.

WHAT IS EXPECTED TO BE ACHIEVED?

LIST OTHER POTENTIAL FUNDING SOURCES FOR THIS PROJECT WHOM YOU HAVE CONTACTED (e.g. corporations, foundations, individuals - indicate amount sought from each)

BRIEFLY DESCRIBE THE POPULATION THAT WILL BE SERVED BY THIS PROJECT

SERVICE WITHIN FOUNTAIN VALLEY

Number of different persons served by the organization _____

Seniors 65 and over _____

Adults 19-64 _____

Under 18 _____

Total persons served _____

Number of Fountain Valley individuals served by the organization _____

Percentage of Fountain Valley served as percentage of agency's total number served _____



Legal Name of Organization: Fountain Valley Royal Regiment Boosters Association

Date of IRS Exemption: 1993

Address: P.O. Box 20168

City, State, Zip: Fountain Valley, CA 92728

Phone: (626) 242-3311

Website: <http://www.fvhsmusic.com>

Name of Executive Director: Christine Nguyen

Applicant Name: Jackson Lai

Applicant Title: Director of instrumental Music, FVHS

Applicant Phone: 626-242-3311

Applicant Email: JLai@hbuhd.edu

Number of Paid Full-Time Staff: 0

Number of Paid Part-Time Staff: 9

IRS Classification: 501(c)3 - Public Charity

Briefly bullet point your key Programs and Services.

Instrumental Music, Fountain Valley High School music ensembles:

Marching Band (Royal Regiment)

Concert Band

Philharmonic Strings (advanced orchestra)

Concert Strings (beginning orchestra)

Percussion ensemble

Colorguard

Jazz Band

Brass Ensemble

Rock Band

Briefly state what makes your Program unique.

Our program is unique because it is the only program in our district of 6 high schools that is increasing in size and continually expanding as a music program. Additionally, our music program extends itself as ambassadors in music for our high school and local community. We fulfill our mission and serve our purpose by honoring our armed forces and those who have sacrificed for the betterment of our society, celebrating accomplishments and commemorations, and mourning sacrifices. Our students learn multiple styles of music and are provided a music education that will prepare them for further musical studies beyond high school so that they are prepared for their futures.

The Concert Band has grown from 48 students to 65 students over the past 2 years.

The Orchestra program has grown from 39 students to 70 students over the past 5 years.

Our marching band grew from 62 students to 78 students in 1 year and is expected to grow to 90+ in the next year.

Our indoor percussion ensemble grew from 16 students to 28 students this past year.

We participate in many key events for our community, including attributing over 130 participants in the Hyundai 5k run in September, representing Fountain Valley in national level parades and performances such as the Pearl Harbor Memorial Parade in Hawaii, the Memorial Day Parade in Washington DC, performances in internationally recognized concert halls such as the Segerstrom Center for the Arts performance hall, the Samueli Hall, Sonoma's Green Music Center, and the Carpenter Performing Arts Center in Long Beach. We also focus on honoring and paying respect to our local community, performing in the Tet festival at Costa Mesa fairgrounds, the Tet parade in Westminster, and other local events such as

Future performances include venues such as Carnegie Hall in New York, parades in London, concert halls in Prague, and different major hubs in the United States such as Seattle, Chicago, and other locations.

Briefly describe the Organization's Key Initiatives, Accomplishments and/or Challenges over the Past Two Years.

As a music program, our mission is to provide our students with an exceptional musical and cultural experience, promoting and fostering teamwork, self-discipline, and leadership while demonstrating artistic excellence in representation of our program to create an everlasting legacy. This experience includes performing with passion, learning with purpose, and connecting with diverse communities, and building lifelong friendships & memories for every member of our music program.

Some challenges included student participation, but it has been improving and more students are in the ensemble. Quality of instruments and equipment have always been a challenge and we have been focused on replacing or adding new instruments. Our cello section grew from 9 students to 16 students and we do not have enough cellos for the students to play on.

Accomplishments over the past 2 years include:

Marching Band, 2024: CSBC Division 3A State Champions, Combined 1A-3A State finals Silver medalist
Marching Band, 2025: CSBC Division 4A State 6th place, Combined 4A-6A State finals Finalist

Concert Band, 2024:

Worldstrides Festival, Excellent rating

Music for All Western Concert Band Festival, Superior rating

Concert Band, 2025:

SCSBOA Concert Band Festival, Superior rating

Orchestra, 2024:

Worldstrides Festival, Outstanding Orchestra performance

SCSBOA Orchestra Festival, Superior Rating

RCC Orchestra Festival, Superior rating

OC Philharmonic Society Orchestra Festival, Superior rating

Orchestra, 2025:

SCSBOA Orchestra Festival, Superior Rating

RCC Orchestra Festival, Superior rating

OC Philharmonic Society Orchestra Festival, Superior rating

Briefly describe the Project for which funding is sought.

Our project is Instrument and Equipment Update and Upgrade.

With a music program as celebrated as ours at Fountain Valley High School, instruments will always be a top priority for our program. Instruments last decades, but the instruments purchased from the 70s, 80s, and 90s are already beyond 20 years in age and most are falling apart. Our instrumental music program prides itself in providing students with an opportunity to receive an outstanding music education. The quality of our instruments are at the point where they are limiting our students from reaching further in their potential and we need to upgrade and improve our instrument inventory so that we have enough quality instruments to ensure that our students receive the best in everything that we are able to provide.

Amount Requested from FVCF: \$15,000

Total Project Budget: \$15,000

Is this project part of a bigger project? N

What is expected to be achieved?

We will be purchasing new instruments for our students - primarily brass, woodwind, rock band and string instruments.

List Other Potential Funding Sources for this Project whom you have contacted.

None for this solo project request.

Briefly describe the Population that will be served by this Project.

The population that will be served by this project will be high school students grades 9 - 12 at Fountain Valley High School. The instruments from this purchase will last at least 20 years and serve generations of future Fountain Valley High School students.

Hundreds of students will benefit from this project as performers and audiences all around the community and the world will be able to experience live music performances from our students.

Number of different persons served by the organization: 250+

Seniors 65 and over: 0

Adults 19-64 years of age: 0

Under 18 years of age: 250+

Total persons served: 250+

Friends and colleagues,

I am reaching out to a select circle who knew and respected Chief Bill McQuaid, and who understand the depth of his impact on the fire service and the communities he served.

Bill's career was defined by steady leadership, humility, and an resolute commitment to others. He dedicated his life to public service, mentoring generations of firefighters, strengthening the departments he led, and earning the respect of peers across the region. Beyond his titles and accomplishments, he was a trusted friend, and calming presence. His influence continues to live on in the people he shaped and the culture he helped build.

Chief McQuaid's wife, Tracy, and the city are working to install a memorial bench at the location of Bill's final surf — a place that symbolizes the balance he found between a demanding career and the personal passions that grounded him. The attached concept design reflects a simple, dignified tribute intended to give family, friends, and members of the fire service a permanent place to pause, reflect, and remember a life devoted to service.

The anticipated cost of the bench and installation is approximately \$2,400. The Fountain Valley Firefighters Association has already committed \$500 toward the project. I am inviting this small, hand-selected group to consider helping complete the effort. There is no expectation — only an opportunity to participate if you feel moved to do so. Any contribution, large or small, helps ensure that Bill's legacy is honored in a way that matches the respect so many of us hold for him.

If you would like to contribute or would like additional details, please let me know.

Thank you for taking a moment to remember Bill and for considering being part of this tribute to a remarkable leader, mentor, and friend.

FRONT ELEVATION

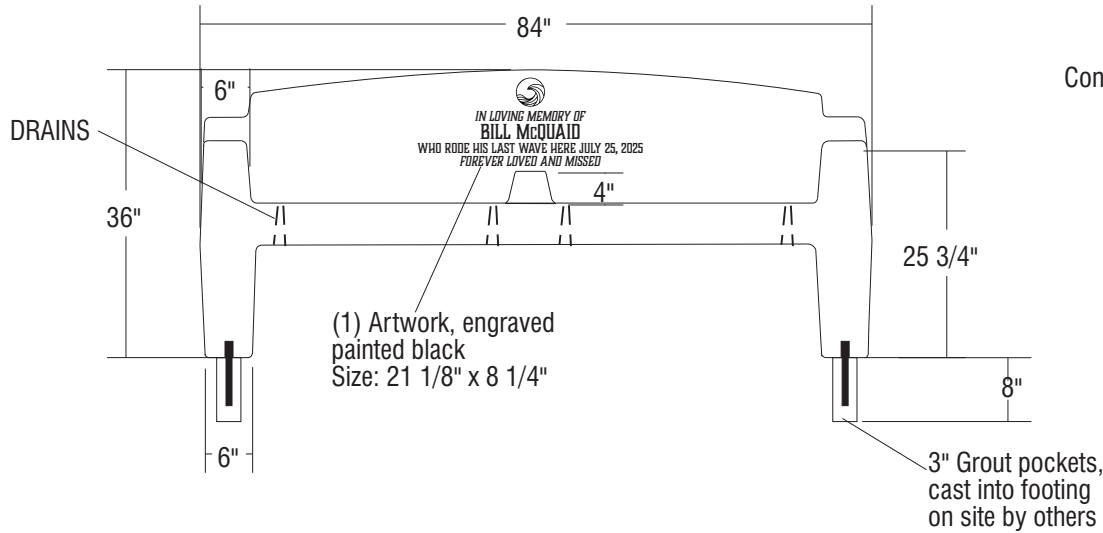

SECTION

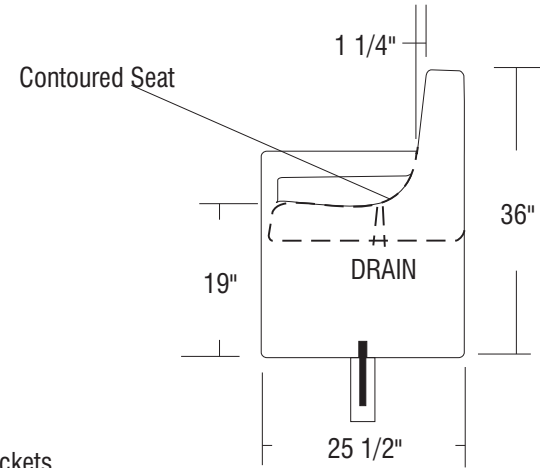

REAR ELEVATION

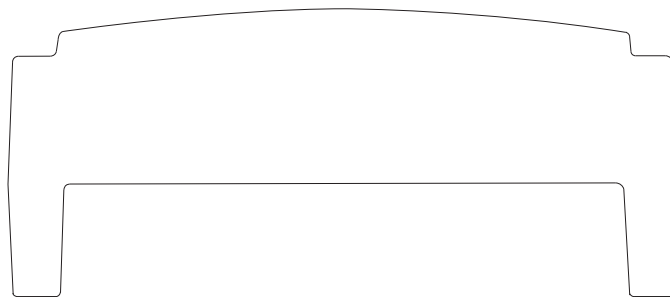

*Epoxy coated rebar

NOTES:

1. Concrete mix design to include a mixture of Portland Cement, water, coarse and fine aggregates, pure mineral oxide coloring agents (when applicable) to yield a minimum compressive strength of 5000 psi.
2. Final product shall be reinforced with #4 and #5 rebar grid.
3. Product is cast in 1-piece with no assembly required.
4. Hairline cracks may develop over time. These are not structural failures, but inherent characteristics of the material itself.
5. Air pockets are a common occurrence in precast products. The frequency and size of air pockets are variable and to be expected, especially on vertical surfaces.
6. Concrete corners and edges will chip if not handled according to guidelines. Patch kits are available but may or may not blend and can be variable.
7. There is a level of care and maintenance associated with your product and is the responsibility of the end user. Choosing the right sealer can help minimize those costs.

BENCH INSTALLATION::

This bench model will have cast in threaded inserts in the bottom of each leg. Bench will be supplied with coilrod for mechanical attachment, as an additional security method.
 **Bench requires epoxy applied to cover bottom of entire leg. Epoxy adhesive should be checked periodically to ensure continued adhesion.

- *Threaded inserts in legs for mounting dowels (1 per leg).
- (2) 3/4" x 8" coilrods provided per bench for mounting.

WEIGHT: 2000 LBS
 TEXTURE: Light Sandblast
 COLOR: ODC Medium Gray
 SEALER: Non-Sacrificial
 Graffiti Coating

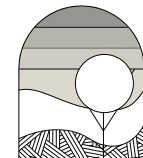

**OUTDOOR
 CREATIONS
 INC.**
 2270 Barney Street
 Anderson, CA 96007
 (530) 365-6106
 FAX (530) 365-5129

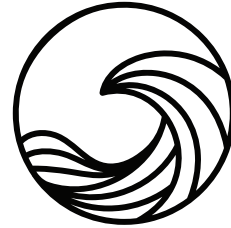

IN LOVING MEMORY OF
BILL McQUAID
WHO RODE HIS LAST WAVE HERE JULY 25, 2025
FOREVER LOVED AND MISSED

(1) Artwork, engraved
painted black
Size: 21 1/8" x 8 1/4"

PLEASE NOTE:

It is **VERY IMPORTANT** to carefully read over your artwork, this includes, but is not limited to, the spelling of names, dates, places, logos, etc. Outdoor Creations Inc. is not liable for replacement of product, if artwork has been approved. Replacement of product that was approved with incorrect spellings, dates, logos, etc will be the responsibility of the customer. Thank you for your understanding.

I have read the above statement and approve the artwork: _____

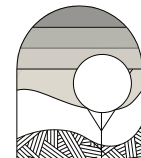

**OUTDOOR
CREATIONS
INC.**

2270 Barney Street
Anderson, CA 96007
(530) 365-6106
FAX (530) 365-5129



(For illustration purposes only, leg widths and spacing will differ depending on the model#)

INSTRUCTIONS FOR BENCH INSTALLATION WITH COILROD

****Most bench models will have threaded inserts in bottom of each leg and coilrod will be supplied. Please reference the spec sheet of the model of bench being purchased for additional information.***

- 1) Pour a concrete footing with 3" diameter grout pockets, per spec sheet. Make sure it is flat and level.
- 2) While bench is lifted, thread coilrod (shipped with bench), into threaded inserts in bottom of bench.
- 3) Place bench with coilrods into grout pockets in footing. Do not epoxy yet as a "dry run" to check for proper fit is recommended.
- 4) If bench installs properly then you can proceed to permanent installation that includes application of mortar/epoxy (not supplied by ODC).
- 5) Remove bench with coilrods. Mix mortar and fill grout pockets $\frac{3}{4}$ full with mortar.
- 6) Apply a thick bead of construction epoxy on the bottom of each leg.
- 7) Reinstall bench with coilrods into grout pockets located in footing.
- 8) Use rags/towels to clean up any epoxy that may squeeze out from under the bench as it settles on footing.
- 9) Epoxy adhesive should be checked periodically to ensure continued adhesion.

****The concrete footing/flatwork is the minimum below grade requirement as recommended by Outdoor Creations, Inc. Any additional requirement such as additional height, inset mounting pocket, changes to mounting method for local code requirements, etc. to be the responsibility of the customer. Outdoor Creations Inc. does NOT supply footings and is not liable for footings done by others. By signing below, I (the customer), am responsible for footings done on site.***

CUSTOMER APPROVAL x _____

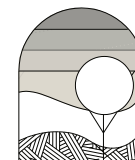

**OUTDOOR
CREATIONS
INC.**

2270 Barney Street
Anderson, CA 96007
(530) 365-6106
FAX (530) 365-5129